

Specifications:
 Actuator platform: ISO 5211
 Overall dimension: MSS SP 67
 Applicable pipe:
 ANSI B36.10, ISO 4200, DIN 2448,
 BS1387-3600, NFA 49004
Technical Data:
 Working pressure: 300 psi
 (20 Bar, 2.0 MPa)
 Range: 2" - 24"
 All valves are tested prior to shipping.
 Sealing test: 110% of working pressure
 Shell test: 200% of working pressure
Factory tested:

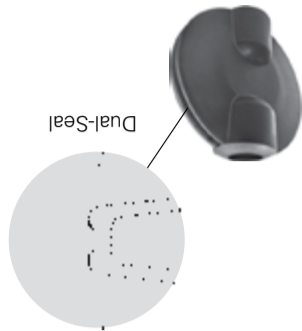

Model SJ-300N-W
 300 psi Butterfly Valve
 with gear operator
 Size range: 2" to 24"



Model SJ-300N-L
 300 psi Butterfly Valve
 with lever handle
 Size range: 2" to 12"



Resilient Seated Butterfly Valve from 2" to 24"
 The Model SJ-300N Butterfly Valve is a grooved-end shut-off valve with outstanding flow characteristic, rated to 300 psi (20 Bar, 2.0 MPa) working pressure. The valve can be supplied with either a 10-position lever handle or a worm gear operator. The epoxy coated ductile iron body and rubber encapsulated dual-seal disc offer a bi-directional bubble tight seal.

MODEL SJ-300N BUTTERFLY VALVE

Part List

10-Position Indicator and Lever Handle

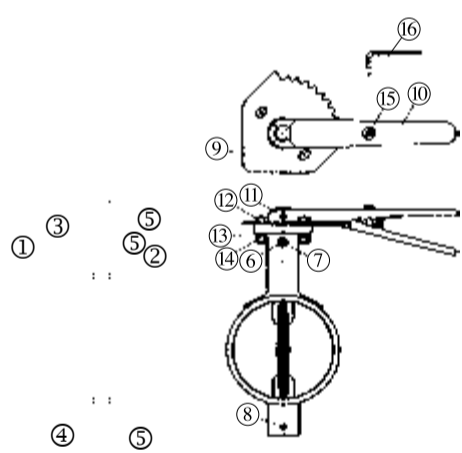

No.	Part Name	Material
1	Body	D.I. A536 Gr. 65-45-12
2	Disc	D.I. A536 Gr. 65-45-12 EPDM Encapsulated
3	Upper Stem	ASTM A582 Type 410
4	Lower Stem	ASTM A582 Type 410
5	O-Rings	EPDM
6	Set Screw	Cr-Mo Steel
7	Hex. Nut	Carbon Steel
8	Spring Pin	Spring Steel
9	10-Position Indicator	D.I. A536 Gr. 65-45-12
10	Lever Handle	D.I. A536 Gr. 65-45-12
11	Spring Pin	Spring Steel
12	Hex. Bolt	Carbon Steel
13	Spring Washer	Spring Steel
14	Hex. Nut	Carbon Steel
15	Lockscrew	Carbon Steel
16	Heptagonal Wrench	Cr-Mo Steel

Worm-Gear Operator

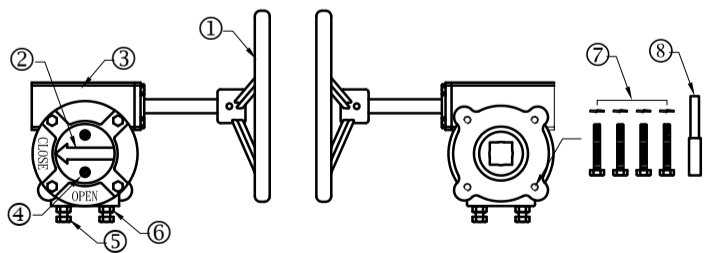

No.	Part Name	Material
1	Handwheel	D.I. A536 Gr. 65-45-12
2	Indicator	Cast Iron A126-B
3	Gear Case	Cast Iron A126-B
4	Adjusting Screw	Carbon Steel
5	Stop Screw	Carbon Steel
6	Fixing Nut	Carbon Steel
7	Set Screws w/ Spring Washers	Carbon Steel
8	Pin Hole Aligner	Carbon Steel

Performance Data / Operating Torque

Worm Gear Operator

Nominal Size	PCD (dia.)	K	S (round □ or square □)	Weight	
				Lbs	Kgs
2	2.75	M8	□ 0.39	9.0	4.1
50	70	M8	□ 0.39	9.0	4.1
2½	2.75	M8	□ 0.39	9.0	4.1
65	70	M8	□ 0.39	9.0	4.1
3	2.75	M8	□ 0.39	9.0	4.1
80	70	M8	□ 0.39	9.0	4.1
4	2.75	M8	□ 0.47	9.0	4.1
100	70	M8	□ 0.47	9.0	4.1
5	2.75	M8	□ 0.47	9.0	4.1
125	70	M8	□ 0.47	9.0	4.1
5	2.75	M8	□ 0.63	9.0	4.1
125	70	M8	□ 0.63	9.0	4.1
8	2.75	M8	□ 0.63	9.0	4.1
200	70	M10	□ 0.94	12.3	5.6
10	4.00	M10	□ 0.94	12.3	5.6
250	102	M10	□ 0.94	12.3	5.6
12	4.00	M10	□ 0.94	12.3	5.6
300	102	M10	□ 0.94	12.3	5.6
14	4.90	M12	□ 0.94	32.8	14.9
350	125	M12	□ 0.94	32.8	14.9
16	5.50	M16	□ 1.44	32.8	14.9
400	140	M16	□ 1.44	32.8	14.9
18	5.50	M16	□ 1.625	32.8	14.9
450	140	M16	□ 1.625	32.8	14.9
20	6.50	M20	□ 2.04	67.1	30.5
500	165	M20	□ 2.04	67.1	30.5
22	6.50	M20	□ 2.04	67.1	30.5
550	165	M20	□ 2.04	67.1	30.5
24	6.50	M20	□ 2.04	67.1	30.5
600	165	M20	□ 2.04	67.1	30.5

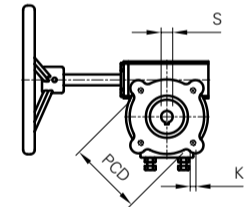

10-Position Indicator and Lever Handle

Nominal Size	PCD (dia.)	K (dia.)	S (square)	Weight	
				Lbs	Kgs
2	2.75	M8	□ 0.39	9.0	4.1
50	70	M8	□ 0.39	9.0	4.1
2½	2.75	M8	□ 0.39	9.0	4.1
65	70	M8	□ 0.39	9.0	4.1
3	2.75	M8	□ 0.39	9.0	4.1
80	70	M8	□ 0.39	9.0	4.1
4	2.75	M8	□ 0.47	9.0	4.1
100	70	M8	□ 0.47	9.0	4.1
5	2.75	M8	□ 0.47	9.0	4.1
125	70	M8	□ 0.47	9.0	4.1
6	2.75	M8	□ 0.63	9.0	4.1
150	70	M8	□ 0.63	9.0	4.1
8	2.75	M8	□ 0.63	9.0	4.1
200	70	M10	□ 0.94	12.3	5.6
10	4.00	M10	□ 0.94	12.3	5.6
250	102	M10	□ 0.94	12.3	5.6
12	4.00	M10	□ 0.94	12.3	5.6
300	102	M10	□ 0.94	12.3	5.6

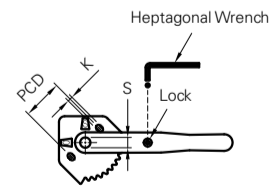

Operating Torque (SJ-300N-W)

Nominal Size	Torque	
	In-Lbs	Nm
2	80	9
50	80	9
2½	120	14
65	14	14
3	160	18
80	18	18
4	450	51
100	51	51
5	700	79
125	79	79
6	900	102
150	102	102
8	1200	136
200	136	136
10	1800	203
250	203	203
12	2500	283
300	283	283
14	3000	339
350	339	339
16	4000	452
400	452	452
18	5500	622
450	622	622
20	8000	904
500	904	904
22	8750	986
550	986	986
24	9500	1074
550	1074	1074

Notes: The torque values are based on liquid applications. For dry or non-lubricating applications add a 25% service factor to the above values.

Nominal Pipe Size	Valve Body Dimensions		D	C	B	A	E	F	Weight
	In	mm							
2	2.375	3.19	2.48	4.17	7.56	80	6.8	6.00	13.6
50	60.3	81	63	106	9	9	3.1	152	6.2
2½	2.875	3.82	3.11	4.37	7.56	120	8.2	6.00	14.3
65	73.0	97	79	111	14	14	3.7	152	6.5
3	3.000	3.82	3.11	4.37	7.56	120	8.4	6.00	14.3
76.1 mm	76.1	97	79	111	14	14	3.8	152	6.5
5	5.630	3.82	3.11	4.37	7.56	120	8.4	6.00	14.3
125	141.3	148	145	168	79	79	7.7	152	9.9
5	5.630	3.82	3.11	4.37	7.56	120	8.4	6.00	14.3
139.7 mm	139.7	148	145	168	79	79	7.7	152	9.9
5	5.630	3.82	3.11	4.37	7.56	120	8.4	6.00	14.3
165.1 mm	165.1	148	145	168	79	79	7.7	152	9.9
6	6.425	5.83	6.77	4.49	7.24	900	9.2	6.00	25.3
150	168.3	148	172	184	260	102	9.2	152	11.4
200 JIS	8.516	5.24	8.74	5.51	10.24	1200	12.2	6.00	31.9
8	8.625	5.24	8.74	5.51	10.24	1200	12.2	6.00	31.9
200	219.1	133	222	140	208	136	12.2	152	14.5
10	10.750	6.25	10.86	6.69	9.25	1800	14.2	8.00	59.4
250	273.0	159	170	170	235	204	14.2	203	27.0
12	12.750	6.53	12.87	8.07	10.24	2500	14.2	8.00	73.7
300	323.9	166	170	170	235	204	14.2	203	27.0
14	14.000	7.00	14.37	8.82	10.86	282	14.2	8.00	80.0
350	355.6	178	178	178	242	242	14.2	203	33.5
400	406.4	178	178	178	242	242	14.2	203	33.5
18	18.000	8.00	18.50	9.25	13.78	350	14.2	8.00	88.0
450	457.2	203	203	203	242	242	14.2	203	36.0
18	18.000	8.00	18.50	9.25	13.78	350	14.2	8.00	88.0
400	406.4	178	178	178	242	242	14.2	203	33.5
400	406.4	178	178	178	242	242	14.2	203	33.5
24	24.000	10.00	24.76	14.49	17.83	453	14.2	8.00	160.0
550	559.0	235	235	235	242	242	14.2	203	36.0
22	22.000	9.25	22.75	13.48	16.81	427	14.2	8.00	147.0
500	508.0	216	216	216	242	242	14.2	203	36.0
20	20.000	8.50	20.75	12.36	15.08	383	14.2	8.00	133.0
500	508.0	216	216	216	242	242	14.2	203	36.0
20	20.000	8.50	20.75	12.36	15.08	383	14.2	8.00	133.0
16	16.000	7.00	16.38	9.76	11.89	302	14.2	8.00	117.0
24	24.000	10.00	24.76	14.49	17.83	453	14.2	8.00	160.0

Worm Gear Operator Installation

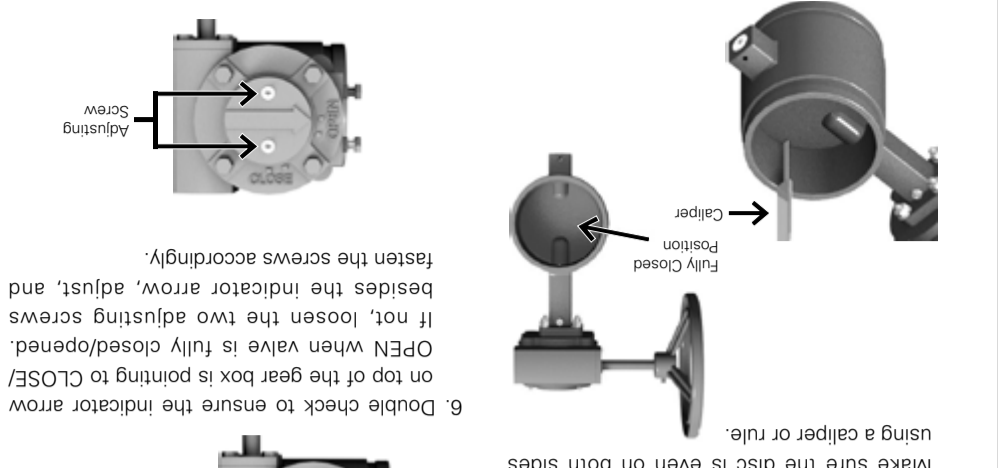

- Affix the handwheel to the gear box axis by inserting the spring pin. Use the factory supplied pin hole aligner to help align the pinholes of the handwheel and the gear box axis.
- Affix the gear box with the four set screws supplied.
- Turn the valve disc to fully closed position. Make sure the disc is even on both sides using a caliper or rule.
- Fasten the stop screw on the right (of the word "OPEN" on the gear box) at fully closed position. The fully closed position is now set up.
- Turn the disc to fully opened position making the valve disc perpendicular to valve body. Fasten the set-screw on the left to set up fully opened position.
- Turn the valve disc to fully closed position. Double check to ensure the indicator arrow on top of the gear box is pointing to CLOSE/OPEN when valve is fully closed/opened. If not, loosen the two adjusting screws besides the indicator arrow, adjust, and fasten the screws accordingly.

Valve size	Gear Box	Screw	Qty
2" ~ 8"	WGO-0	M8	4
10" ~ 12"	WGO-1	M10	4
14"	WGO-3	M12	4
16" ~ 18"	WGO-3	M16	4
20" ~ 24"	WGO-4	M20	4

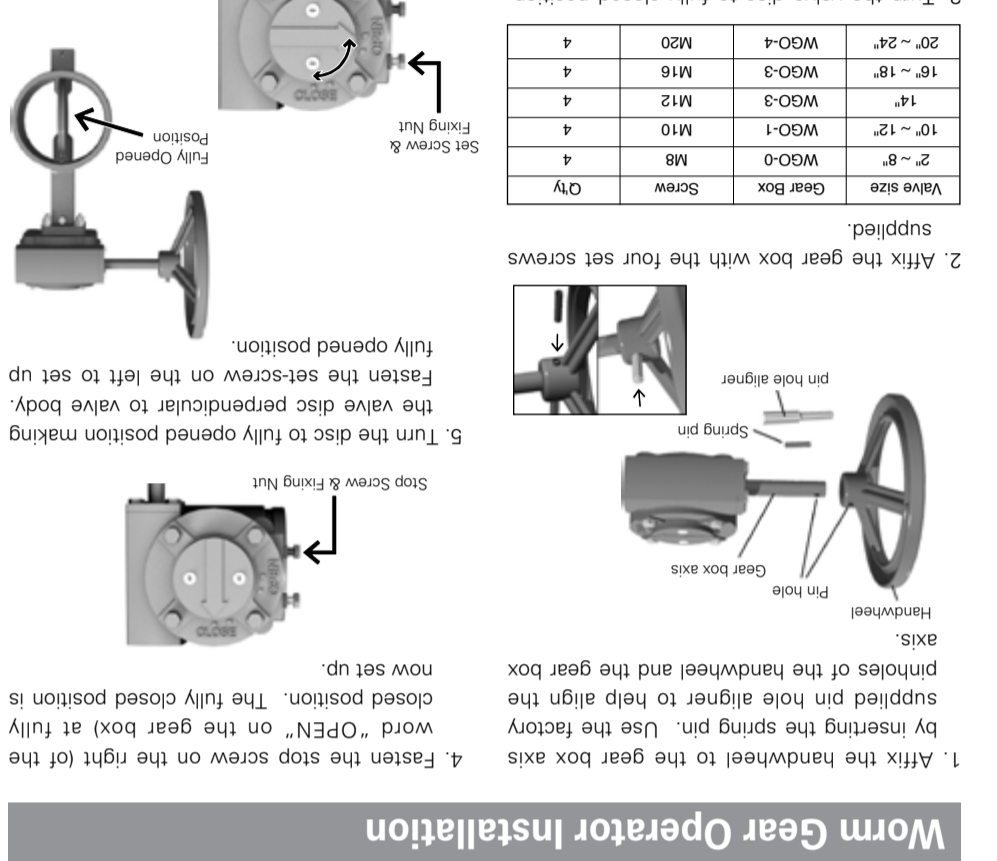

Lever Handle Installation

- As supplied, the lever handle is disassembled and the 10 position indicator is not firmly affixed on the valve.
- Mount the lever handle on the stem. Do not tighten the set screws yet.
- Turn the lever handle until the disc comes to the fully closed position.
- Make sure that the lever is positioned to point 'S' on the 10 position indicator plate.
- Tighten the nuts firmly and affix the 10 position indicator plate on the valve.
- Affix the lever handle to the valve stem by inserting the spring pin.

*** Reverse Installation of Lever Handle**

You may mount the lever handle on the reverse side of the valve only when it is absolutely necessary. Detach the lever handle and indicator plate, and reposition the indicator plate 180° on the opposite side. Then install the lever handle in the same manner as mentioned in 2 - 6.

Caution: Do not detach the indicator plate.

Caution: The manufacturer strongly recommends repositioning the entire valve instead of reversing the lever handle.

Warning: Repositioning of the indicator plate other than 180° may cause malfunction.

Mounting Instructions

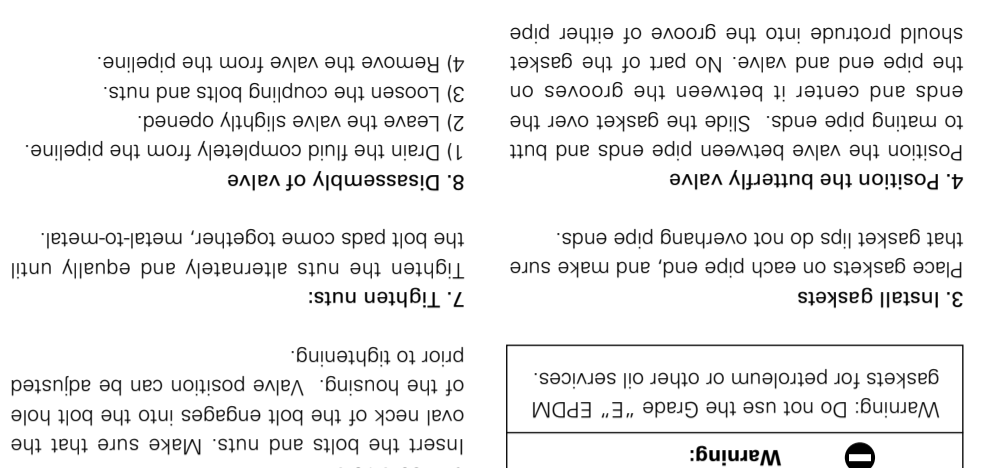

- Pipe End Preparation**
Prepare the right OD pipe to match the valve or valve. The gear-operator should be in a position that an observer can see the indicator clearly and can tell that the valve is open or closed.
- Lubricate gaskets**
Apply thin coat of lubricant to gasket lips and complete exterior of gaskets.
- Install gaskets**
Place gaskets on each pipe end, and make sure that gasket lips do not overhang pipe ends.
- Position the butterfly valve**
Position the valve between pipe ends and butt to mating pipe ends. Slide the gasket over the ends and center it between the grooves on the pipe end and valve. No part of the gasket should protrude into the groove of either pipe.
- Install coupling halves**
Place the coupling halves over the gasket and make sure that the coupling keys are engaged into the grooves.
- Insert bolt**
Insert the bolts and nuts. Make sure that the oval neck of the bolt engages into the bolt hole of the housing. Valve position can be adjusted prior to tightening.
- Tighten nuts**
Tighten the nuts alternately and equally until the bolt pads come together, metal-to-metal.
- Disassembly of valve**
1) Drain the fluid completely from the pipeline.
2) Leave the valve slightly opened.
3) Loosen the coupling bolts and nuts.
4) Remove the valve from the pipeline.

Warning: Do not use the Grade "E" EPDM gaskets for petroleum or other oil services.

Maintenance / Flow Data

Maintenance Instructions

The Model #SJ-300N Butterfly Valves require no regular maintenance. We do however recommend that you periodically inspect and verify proper operation of the unit on an annual basis or in accordance with the local authority(s) having jurisdiction. The inspection should include visual check for leakage at the valve pipe connection and the body to operator connection. Inspection and maintenance should be performed by qualified inspection personnel.

Caution: Depressurize and drain the pipeline system Always depressurize and drain the pipeline system before disassembly and removal of any component(s). Failure to do so could result in serious personal injury, joint leakage and or property damage.

Caution: Valves should be handled carefully to avoid any damage, especially to the seating area. If a valve tends to close hard, it usually indicates debris is lodged in the seating area. In such a case, back off the hand wheel and attempt to close the disc again.

Warning: Do not use a wrench or other tool on the handwheel when opening or closing the valve as this may distort the valve components or score the seating surface. The pipeline should be properly supported to prevent excess stress on the valve body.

Flow Data

Equivalent length and Cv values for flow of water are shown below (water temperature at +20°C or +68°F).

Nominal Size (in)	Equiv. Length of Sch. 40 pipe*		Cv Values
	Feet	Meter	
2	4.7	(1.4)	120
2½	5.2	(1.6)	210
3	5.5	(1.7)	380
4	6.8	(2.1)	720
5	8.5	(2.6)	1150
6	7.4	(2.3)	2000
8	9.2	(2.8)	3800
10	13.5	(4.1)	5500
12	15.1	(4.6)	8250
14	19.6	(6.0)	9500
16	21.8	(6.6)	13000
18	23.8	(7.3)	16000
20	27.3	(8.3)	20000
22	30.5	(9.3)	24000
24	33.7	(10.3)	29000

*At 15 feet/sec. (4.6m/s) Velocity of water.

